

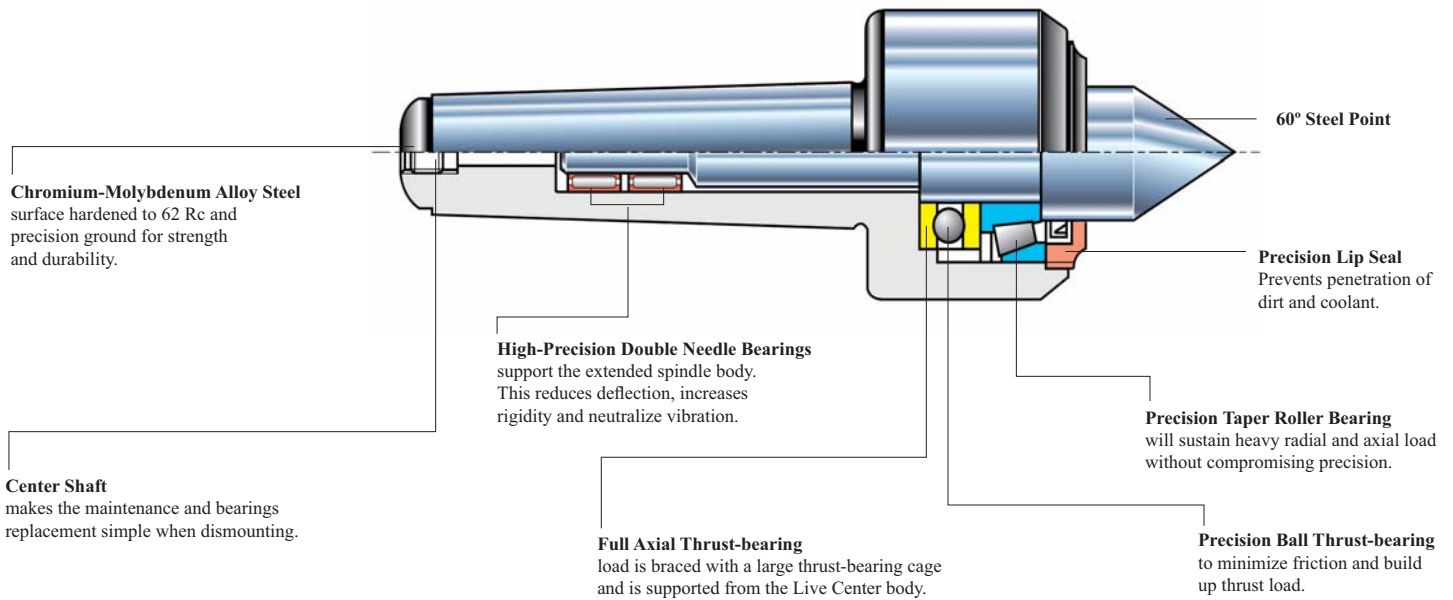

# Perfetta™ Heavy Duty Live Center

- FOUR BEARINGS
- HIGH ACCURACY
- MEDIUM SPEEDS
- HEAVY DUTY APPLICATION
- LIFE TIME LUBRICATION
- LONG LIFE



**Heavy Duty Live Center**

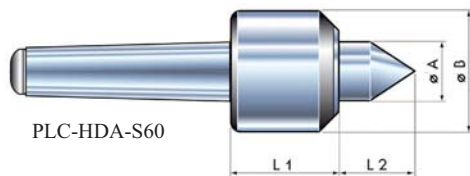

Heavy Duty Live Center		Specifications								
UPC 733101-	Description	A	B	L1	L2	Morse Taper	Weight (lb)	Max. RPM	Max. workpiece weight (lb)	Thrust load (lb)
48206	PLC-HDA-S60-MT2	0.87	201	1.69	0.99	2	1.98	7500	506	1012
48207	PLC-HDA-S60-MT3	0.99	2.17	1.69	1.10	3	2.20	6000	2090	1144
48208	PLC-HDA-S60-MT4	1.14	2.40	2.01	1.50	4	3.52	4500	3300	1320
48209	PLC-HDA-S60-MT5	1.50	3.15	2.32	1.85	5	7.70	2800	4400	2640
48210	PLC-HDA-S60-MT6	1.65	4.26	3.47	2.17	6	22.00	200	10560	3300
48211	PLC-HDA-S60-MT6-S	2.36	5.44	4.57	2.40	6-S	26.40	1700	19800	6600
48212	PLC-HDA-S60-MTM80	2.44	5.75	4.57	2.96	M80	39.60	1100	19800	6600
48213	PLC-HDA-S60-MTM100	3.07	7.01	5.28	3.05	M100	85.80	900	29700	11000