

**90° COUNTERSINK**

Cutting Rake - 11° & 15°  
for 11° & 15° positive triangle TDGH & TPGH inserts

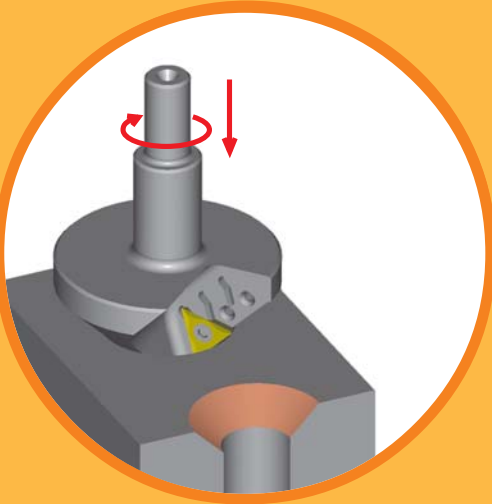

**Milling Application**

Finishing	Medium	Roughing
Best	Good	-

**Insert Type**

Steel	Stainless Steel	Cast Iron	Aluminum	High Temper Alloy
TDGH-EZ TPGH-EZ	TDGH-EZ TPHT-E	TDGH-EZ TPHT-E	TDGH-EZ TPGH-EZ	TDGH-EZ TPHT-E

For insert information see pages E-72 to E-73 & A-72.

**TOOL ANGLES:**

- Cutting Rake +11°/15°
- Axial Rake 0°
- Radial Rake 0°

**FEATURES:**

- Available in 3/8", 1/2", & 3/4" Weldon shank sizes
- Positive triangular inserts, 11° or 15° clearance
- Smoother cutting
- Torx screw locking system
- Three cutting edges



Operation	Tool Rotation	Direction of Cut
90° Countersink	Right Hand	Plunge

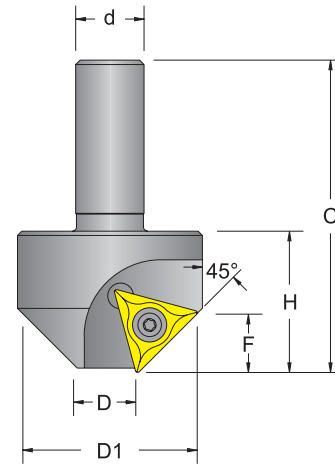

CS90-TD0-000

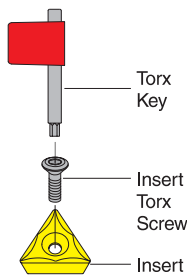

For spare part information see page E-177.

Description	Part No. 733101-	C	d	D	D1	F	H	No. Inserts	Gage Insert	Insert Torx Screw	Torx Key
CS90-TD5-037	65316	2.00	.375	.125	0.500	.185	0.375	1	TDGH 520	TS-06	T-6
CS90-TD2-037	65318	2.25	.375	.250	0.750	.272	1.000	1	TDGH 21.51	TS-25.45-6M1	T-8
CS90-TD3-050	65320	2.50	.500	.500	1.250	.426	1.000	1	TDGH 321	TS-4.7-8M1	T-15
CS90-TP3-075	65323	3.50	.750	.560	2.500	.426	1.250	1	TPGH 321	TS-4.7-8M1	T-15