

## HIGH POSITIVE 90° MILLING CUTTER

Cutting Rake - 20°  
for 11° positive 85° parallelogram AP\_\_ inserts

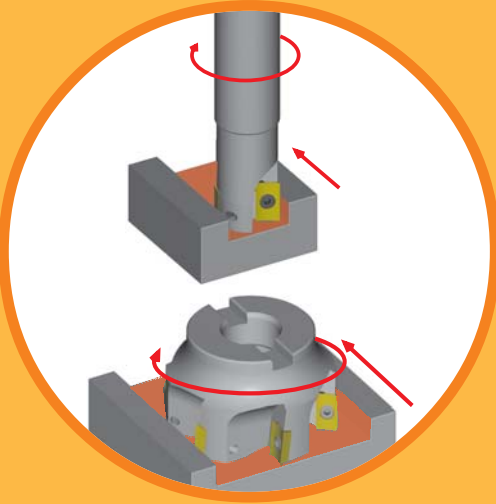

| Operation              | Tool Rotation | Direction of Cut  |
|------------------------|---------------|-------------------|
| 90° End Mill Slot Mill | Right Hand    | Horizontal / Ramp |

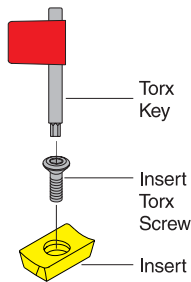

For spare part information see page E-177.

## Milling Application

| Finishing | Medium | Roughing |
|-----------|--------|----------|
| Best      | Good   | Good     |

## Insert Type

| Steel     | Stainless Steel | Cast Iron | Aluminum  | High Temper Alloy |
|-----------|-----------------|-----------|-----------|-------------------|
| APKT-PDER | APKT-PDER       | APHW-PDER | APHX-PDFR | APHX-PDER         |

For insert information see pages E-42 to E-43.

### TOOL ANGLES:

- Cutting Rake +20°
- Axial Rake 6°
- Radial Rake -6°

### FEATURES:

- Available in 3/4", 1.0", & 1.25" Weldon, R8, & arbor shank sizes
- Positive parallelogram inserts, 11° clearance
- 5/8" cutting edge
- Smoother cutting
- Torx screw locking system
- Two cutting edges

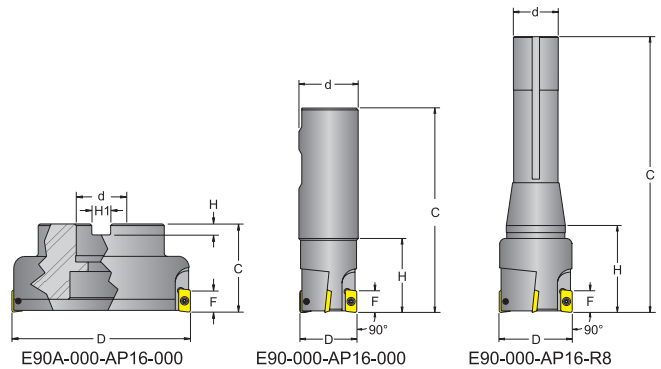

## End Mill

| Description      | Part No. 733101- | C     | D    | d    | F    | H     | No. Inserts | APKT Gage Insert | Insert Torx Screw | Torx Key |
|------------------|------------------|-------|------|------|------|-------|-------------|------------------|-------------------|----------|
| E90-075-AP16-075 | 65644            | 4.000 | 0.75 | 0.75 | .618 | 1.625 | 1           |                  |                   |          |
| E90-100-AP16-075 | 65646            | 4.000 | 1.00 | 0.75 | .618 | 1.625 | 2           |                  |                   |          |
| E90-100-AP16-100 | 65648            | 4.500 | 1.00 | 1.00 | .618 | 1.750 | 2           |                  |                   |          |
| E90-125-AP16-100 | 65650            | 4.500 | 1.25 | 1.00 | .618 | 1.625 | 3           |                  |                   |          |
| E90-150-AP16-100 | 65652            | 4.500 | 1.50 | 1.00 | .618 | 1.625 | 4           | 1604             | TS-4.7-8M1        | T-15     |
| E90-150-AP16-125 | 65654            | 4.500 | 1.50 | 1.25 | .618 | 1.625 | 4           |                  |                   |          |
| E90-200-AP16-125 | 65656            | 4.500 | 2.00 | 1.25 | .618 | 1.625 | 5           |                  |                   |          |
| E90-200-AP16-R8  | 65658            | 5.625 | 2.00 | R8   | .618 | 1.640 | 5           |                  |                   |          |

## Face Mill

| Description       | Part No. 733101- | C    | D   | d    | F    | H    | H1   | No. Inserts | APKT Gage Insert | Insert Torx Screw | Torx Key |
|-------------------|------------------|------|-----|------|------|------|------|-------------|------------------|-------------------|----------|
| E90A-200-AP16-075 | 65662            | 1.57 | 2.0 | 0.75 | .618 | .187 | .312 | 5           |                  |                   |          |
| E90A-250-AP16-100 | 65664            | 1.75 | 2.5 | 1.00 | .618 | .219 | .375 | 5           |                  |                   |          |
| E90A-300-AP16-100 | 65666            | 1.75 | 3.0 | 1.00 | .618 | .219 | .375 | 6           | 1604             | TS-4.7-10M1       | T-15     |
| E90A-400-AP16-150 | 65668            | 2.00 | 4.0 | 1.50 | .618 | .375 | .625 | 8           |                  |                   |          |
| E90A-500-AP16-150 | 65670            | 2.38 | 5.0 | 1.50 | .618 | .375 | .625 | 10          |                  |                   |          |