

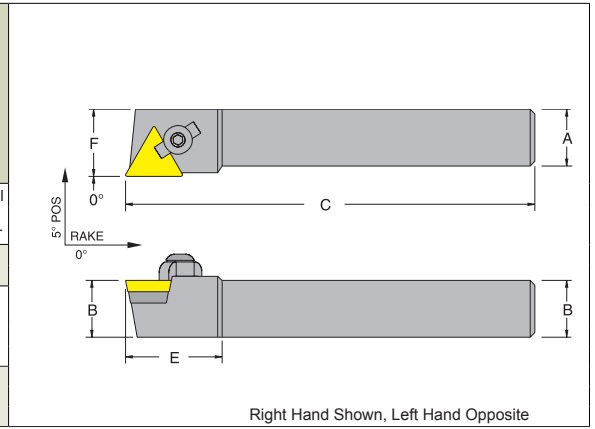

# Clamp Lock Toolholders

Inch Description		Part No. 733101-		TPG Gage Insert						Optional Chip Breaker				
R.H.	L.H.	A	B	C	E	F	Seat	Seat Screw	Clamp	Clamp Clip	Clamp Screw			
CTGPR/L10-3B	51492	51493	0.625	0.625	4.50	1.000	0.875	322	SM-41	TS-4	HC-12	CLP-12	CS-126	T3AE
CTGPR/L12-3B	51496	51497	0.750	0.750	4.50	1.000	1.000	432	SM-37	TS-6	HC-12	CLP-12	CS-126	T4AE
CTGPR/L16-4C	51500	51501	1.000	1.000	5.00	1.250	1.250	543	SM-99	S-10	HC-12	CLP-12	CS-126	T5AE
CTGPR/L16-4D	51504	51505	1.000	1.000	6.00	1.250	1.250							
CTGPR/L20-4D	51508	51509	1.250	1.250	6.00	1.250	1.500							
CTGPR/L85-4D	51512	51513	1.000	1.250	6.00	1.250	1.250							
CTGPR/L16-5D	51516	51517	1.000	1.000	6.00	1.375	1.250							
CTGPR/L20-5D	51520	51521	1.250	1.250	6.00	1.375	1.500							
CTGPR/L24-5E	51524	51525	1.500	1.500	7.00	1.375	2.000							

For inserts see PAGES 16-33. For spare parts see PAGES 112-113.



Inch Description		Part No. 733101-		TPG Gage Insert						Optional Chip Breaker				
R.H.	L.H.	A	B	C	E	F	Seat	Seat Screw	Clamp	Clamp Clip	Clamp Screw			
CTRPR/L10-2B	51534	51535	0.625	0.625	4.50	1.000	0.776	221	-	-	HC-9	CLP-9	CS-96	T2AC
CTRPR/L12-3B	51538	51539	0.750	0.750	4.50	1.250	0.855	322	SM-41	TS-4	HC-12	CLP-12	CS-126	T3AE
CTRPR/L16-3D	51542	51543	1.000	1.000	6.00	1.250	1.105	432	SM-37	TS-6	HC-12	CLP-12	CS-126	T4AE
CTRPR/L85-4D	51546	51547	1.000	1.250	6.00	1.375	1.048							

For inserts see PAGES 16-33. For spare parts see PAGES 112-113.

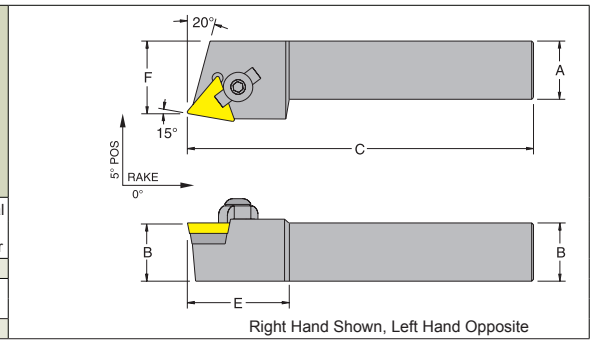

Inch Description		Part No. 733101-		TEGE Gage Insert						Clamp	Clamp Screw
R.H.	L.H.	A	B	C	E	F	TEGE Gage Insert	Clamp	Clamp Screw		
CTAER/L06-7	51380	51381	0.375	0.375	2.50	0.625	0.375	731	HC-7	SHC-7	

For inserts see PAGES 16-33. For spare parts see PAGES 112-113.

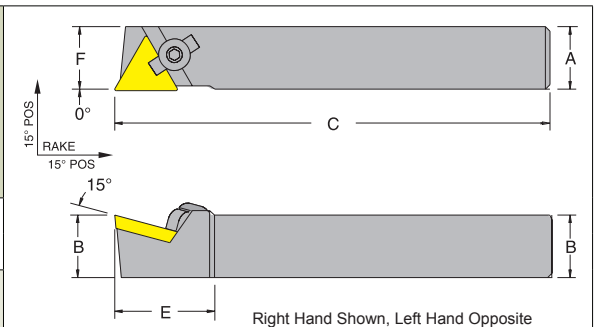

Inch Description		Part No. 733101-		TEGE Gage Insert						Clamp	Clamp Screw
R.H.	L.H.	A	B	C	E	F	TEGE Gage Insert	Clamp	Clamp Screw		
CTCER/L06-7	51418	51419	0.375	0.375	2.50	0.625	0.391	731	HC-7	SHC-7	

For inserts see PAGES 16-33. For spare parts see PAGES 112-113.

