

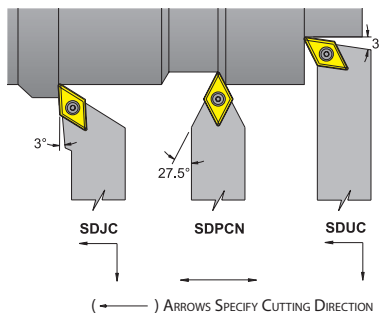

SD - Style Toolholders



Inch Description		Part No. 733101-		A	B	C	E	F	DC_T Gage Insert	Insert Torx Screw	Torx Key
SDJCR/L06-2J		51872	51873	0.375	0.375	3.500	0.688	0.500	21.51	TS-25.45-6M2	T-8
SDJCR/L08-2A		51876	51877	0.500	0.500	4.000	0.688	0.625			
SDJCR/L08-3A		51880	51881	0.500	0.500	4.000	1.000	0.625	32.52	TS-4.7-10M1	T-15
SDJCR/L10-3B		51884	51885	0.625	0.625	4.500	1.000	0.750			
SDJCR/L12-3B		51888	51889	0.750	0.750	4.500	1.000	1.000			
SDJCR/L16-3D		51892	51893	1.000	1.000	6.000	1.000	1.250	432	TS-5.8-10M1	T-20
SDJCR/L12-4B		51896	51897	0.750	0.750	4.500	1.250	1.000			
SDJCR/L16-4D		51900	51901	1.000	1.000	6.000	1.250	1.250			

For inserts see PAGES 16-33. For spare parts see PAGES 112-113.

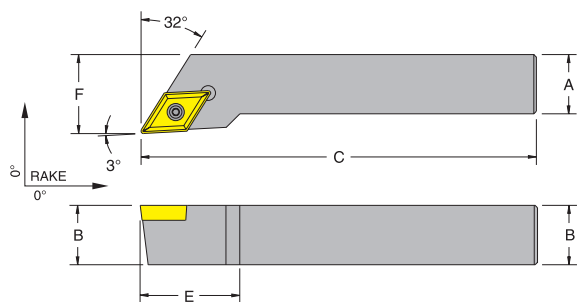

Right Hand Shown, Left Hand Opposite

Inch Description		Part No. 733101-		A	B	C	DC_T Gage Insert	Insert Torx Screw	Torx Key
SDPCN06-2J		NEUTRAL		51910	51910	51910	21.51	TS-25.45-6M2	T-8
SDPCN06-2D		NEUTRAL		51942	51942	51942			
SDPCN08-2A		NEUTRAL		51912	51912	51912			
SDPCN08-2D		NEUTRAL		51943	51943	51943			
SDPCN08-3D		NEUTRAL		51944	51944	51944	32.52	TS-4.7-10M1	T-15
SDPCN10-3B		NEUTRAL		51914	51914	51914			
SDPCN10-3D		NEUTRAL		51945	51945	51945			
SDPCN12-3B		NEUTRAL		51916	51916	51916	432	TS-5.8-10M1	T-20
SDPCN16-3D		NEUTRAL		51918	51918	51918			
SDPCN12-4B		NEUTRAL		51920	51920	51920			
SDPCN16-4D		NEUTRAL		51922	51922	51922			

For inserts see PAGES 16-33. For spare parts see PAGES 112-113.

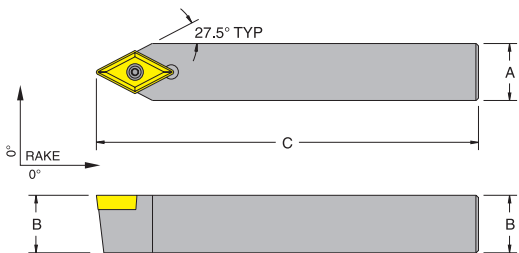

Neutral Hand Shown

Inch Description		Part No. 733101-		A	B	C	E	F	DC_T Gage Insert	Insert Torx Screw	Torx Key
SDUCR/L08-2J		51946	51947	0.500	0.500	3.500	0.500	0.670	21.51	TS-25.45-6M2	T-8
SDUCR/L10-2A		51948	51949	0.625	0.625	4.000	0.500	0.795			
SDUCR/L08-3J		51950	51951	0.500	0.500	3.500	0.688	0.746	32.52	TS-4.7-10M1	T-15
SDUCR/L10-3A		51954	51959	0.625	0.625	4.000	0.688	0.871			

For inserts see PAGES 16-33. For spare parts see PAGES 112-113.

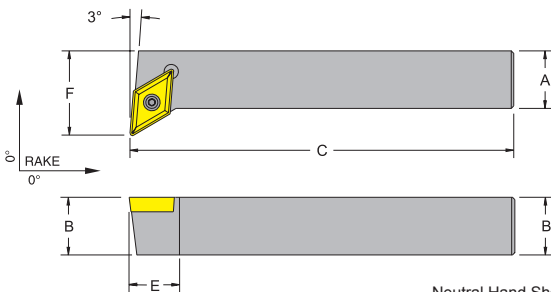

Neutral Hand Shown