

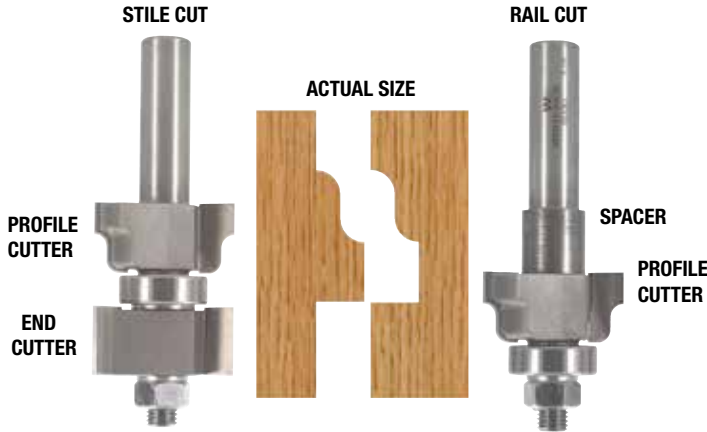

## WINDOW SASH

### WINDOW SASH

This is the only bit you need to make a complete window sash. The bearing guide controls the pattern depth and also allows you to make arched or curved windows and glass doors.



| Part #            | Cutting Dia. | Cutting Length | Overall Length |
|-------------------|--------------|----------------|----------------|
| <b>1/2" SHANK</b> |              |                |                |
| 6050              | 1-3/8"       | 7/8" - 1-5/8"  | 3-5/8"         |

Replacement Parts:  
Arbor: A380  
Bearing Number: B5

Profile Cutter: 6050H  
Straight Cutter: 6050G  
Spacer: 6050SP

### APPLICATION:

This assembly with the straight end cutter cuts the inside edges on both the stiles and rails. Convert the assembly to make the mating end cut by exchanging the straight cutter for the spacer (see drawing above). The spacer can be installed between the profile cutter and the shank if additional reach across the work piece is needed. Now make the mating end cuts on the rails. This bit can also be used to cut both the decorative edges and the mating end cuts required to make your own window mullions (crosspieces).

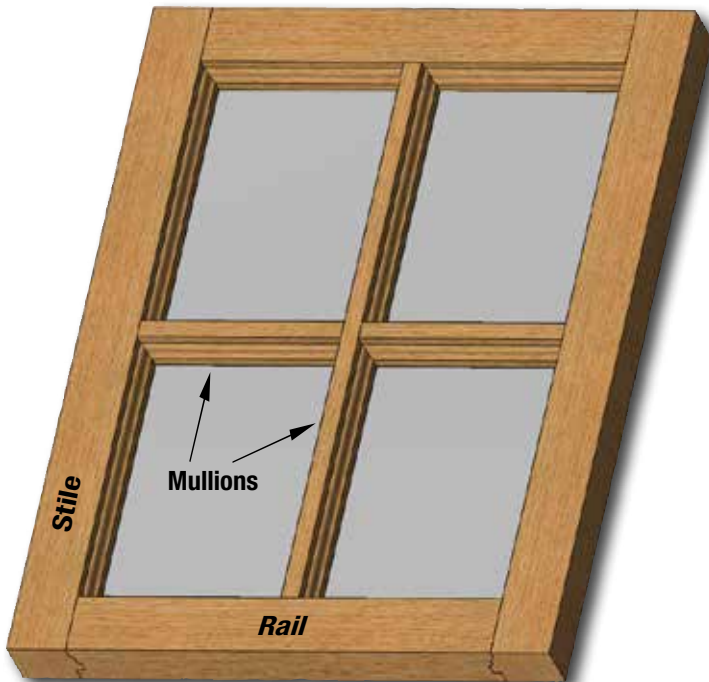

## SLOTING CUTTERS

### SLOTING CUTTERS

1-7/8" Cutting Diameter - 5/16" Bore

| Part # | Part # | Decimal Kerf | Fractional Kerf |
|--------|--------|--------------|-----------------|
| 6700A  | 6700B  | .062         | 1/16"           |
| 6701A  |        | .070         |                 |
| 6702A  |        | .080         |                 |
| 6703A  | 6703B  | .094         | 3/32"           |
| 6704A  |        | .100         |                 |
| 6704C  |        | .110         | 7/64"           |
| 6705A  | 6705B  | .125         | 1/8"            |
| 6708A  |        | .156         | 5/32"           |
| 6709A  |        | .187         | 3/16"           |
| 6709C  |        | .218         | 7/32"           |
| 6710A  | 6710B  | .250         | 1/4"            |
| 6712A  |        | .281         | 9/32"           |
| 6715A  |        | .312         | 5/16"           |



Special sizes available upon request

### SLOTING CUTTER ARBORS

Includes B5 Bearing for 1/2" Depth of Cut.

| Part # | Shank Dia. | Overall Length |
|--------|------------|----------------|
| A200B  | 1/4"       | 2-3/8"         |
| A205B  | 3/8"       | 2-3/8"         |
| A210B  | 1/2"       | 2-5/8"         |
| A220B  | 1/2"       | 4"             |

Note - A220B has an extra long shank for extended reach. All include B5 Bearing for 1/2" depth of cut.

- Use B20 Bearing for 9/16" depth of cut.
- Use B25 Bearing for 3/8" depth of cut.
- Use B26 Bearing for 1/4" depth of cut.
- Use B27 Bearing for 5/8" depth of cut.



## DRAWER SLOT CUTTERS

### DRAWER SLOT CUTTERS

(Jemco Machines)

| Part # | Cutting Dia. | Bore       | Kerf  | # of Flutes |
|--------|--------------|------------|-------|-------------|
| 6800   | 1-1/4"       | 3/8"-24thd | 3/16" | 4           |
| 6801   | 1-1/4"       | 3/8"-24thd | 3/16" | 6           |
| 6805   | 1-1/4"       | 3/8"-24thd | 1/4"  | 6           |



### DRAWER SLOT CUTTER ARBORS

| Part # | Shank Dia. | Overall Length | Thread  |
|--------|------------|----------------|---------|
| 6890   | 1/4"       | 2"             | 3/8"-24 |
| 6891   | 3/8"       | 2"             | 3/8"-24 |
| 6892   | 1/2"       | 2"             | 3/8"-24 |
| 6896   | 3/8"       | 3-1/4"         | 3/8"-24 |

